

Pumping station

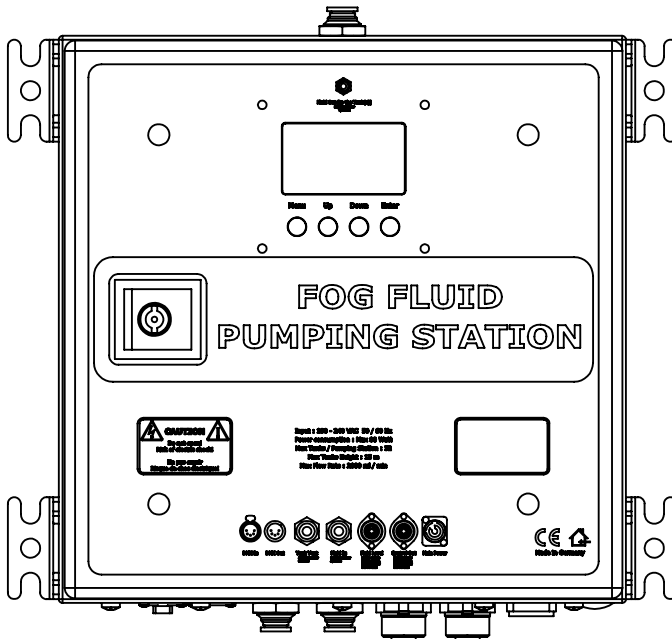

Components

Purchased parts:

- Pumping station
- Mains cable with Powercon connector
- 1 self-locking connector and 1 end fitting

Needed accessories:

- Fluid reservoir with T-connector delivered with hanging yoke or in modified tank holder (to connect to the Look Viper machines)
- Tubes (10 mm PU)
- Barrel lid or lid for 25L-canister with connectors for fluid removal and air vent
- Connectors

Content

1. General	4
2. Operation	5
2.1 Initial operation	5
2.2 Manual operation	6
2.3 DMX/RDM operation	6
2.4 Timer operation	7
2.5 Main menu	9
2.5.1 Status	
2.5.2 Time-Blocks	
2.5.3 Sensors	
2.5.4 Options	
3. Error indication	13
4. Technical data	13
5. Fluid reservoir	14
6. Warranty regulations	15

1. General

The Pumping station supplies fog fluid to up to 32 connected haze- or fog generators in up to 15 m heights.

The machines therefor have to be equipped with special fluid reservoirs. With the quick acting coupling the reservoirs can be easily connected to all (Look-)machines.

For the Viper nt and Viper 2.6 the fluid reservoir comes with a modified tank holder, otherwise the fluid reservoir is equipped with a hanging yoke.

The reservoirs have capacity for an adequate amount of fluid - and will be refilled from the pumping station if necessary - to avoid that the connected machines can run dry.

The system is endowed with mechanical protections to avoid an overfilling of the fluid reservoirs. If the tube should have a leakage, the Pumping station switches off after a time that can be individual programmed by the user (**important: see point 2.5.3 Options!**).

Electronic sensors can additionally be connected.

The Pumping station is equipped with a DMX/RDM function. Thus, the DMX address can be also adjusted at an RDM-compatible desk and some other adjustments can be done.

The Pumping station can be controlled manual, via DMX or the internal timer. The timer can be divided into 16 blocks where different start- and stop-times can be programmed in.

2. Operation

2.1 Initial operation

The assignments of the keys are as follows:

- MENU:** Retrieving the main menu
UP-/DOWN: Selecting the submenu and changing the data
ENTER: Activating the submenu, going to the next adjustable data, saving adjusted data.

The data that can be adjusted, flashes.

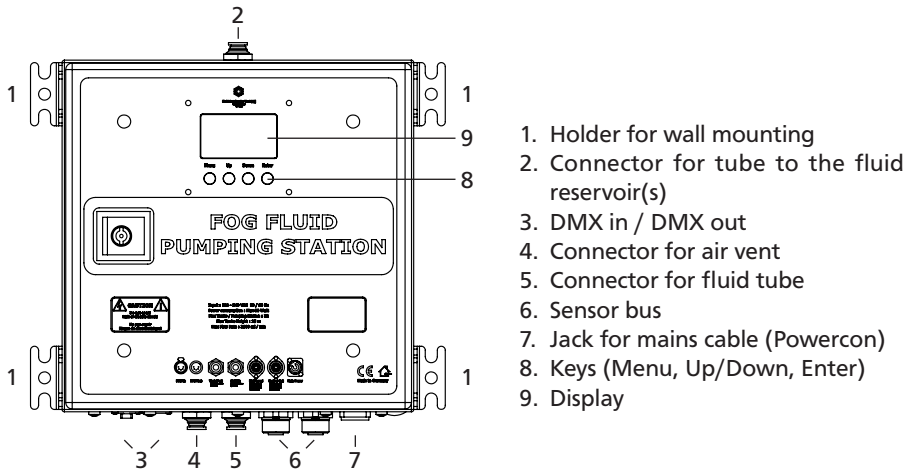

1. Screw the special lid onto the barrel or canister and then connect it to the pumping station by using the 10mm PU-tube. Therefore use the correct connector [5] at the pumping station. Connect also the second tube for the air vent at the right connector [4]. At the lid, the tube for the fluid removal has to be connected at the top, the tube for the air vent at the side of the lid.
2. Connect the Pumping station to the fluid reservoir, using the right connector [2]. If several machines have to be supplied with fluid, the fluid reservoirs have to be connected via PU-tubes and connectors (see chapter 4).

TIP: If the Pumping station will be installed and removed now and then (f.e. at touring), connect a short piece of the PU-tube to connector 2 and on the other end the sup-

2. Operation

plied self-locking connector (**long side of the connector connected to the short tube!**).

If the Pumping station will be removed, disconnect the long side (important!!!) of the connector and connect the delivered end piece to the short tube.

Now, no fluid can drain out of the rising pipe or the Pumping station.

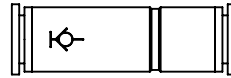

Self-locking connector



End piece

- Adjust the fluid reservoirs by using the installed water-bubble in the reservoirs lid. The bubble has to be located exactly in the middle.
- Connect the mains cable to the jack [7] at the Pumping station and a socket. The Pumping station switches on automatically.
- Check the time showing on the display and change it if needed (day, hrs, min). Press the „Enter“-button to change from day to hour and minute, the „Up“ (+) - and „Down“ (-) -buttons to adjust the value.

ATTENTION: the Pumping station only shows the European 24 hours! For the pm-time you have to add 12 hours to get the 12 hrs time.

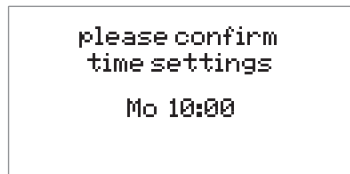

Fig. 1 Start menu - time setting

Approx. 10 seconds after the last adjustment is done, the display change to the status menu (fig. 2).

2. Operation

2.2 Manual operation

1. Activate the Pumping station by pressing the „Enter“-button briefly. „active“ appears at the display.

The Pumping station now pumps fluid into the connected fluid reservoirs, until they are filled. The lock inside the reservoir realise when it is filled and the Pumping station stops pumping.

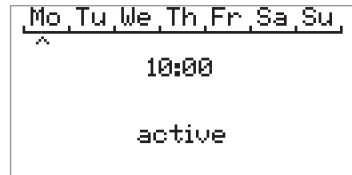

Fig. 2 Status menu - machine active

Once the fogging process has been started the reservoirs will drain and the Pumping station refills them automatically.

2. Pressing the „Enter“-button again will deactivate the Pumping station. „not active“ appears at the display.

Doing so, a bleed valve will open and some of the fluid in the riser drains.

If the whole fluid shall be draining (f.e. if the station is removed), air has to be let into the tube system.

This is done by letting the connected fog machines run while the Pumping station is deactivated. The fluid level sinks and will not be refilled by the Pumping station. The float sinks and air can get into the tube. The fluid in the tubes drains.

The fluid in the reservoirs will not drain. After three minutes the valve closes automatically.

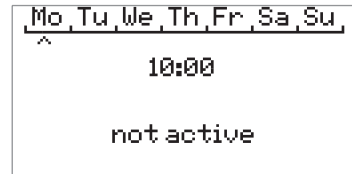

Fig. 3 Status menu - machine not active

If the Pumping station will be mounted and removed more often, please note the TIP on page 5/6.

2. Operation

2.3 DMX/RDM operation

1. Connect the Pumping station to a DMX-desk.
Use the right jack at the bottom [3].
A RDM-controller can also be connected.
2. Press the „Menu“-button to get into the main menu, select the menu „Options“ with the „Up“-/„Down“-buttons and activate it by pressing the „Enter“-button shortly.

Select „DMX-adr.“ with the „Up“-/„Down“-buttons. The figures start flashing and can be adjusted using the „Up“-/„Down“-buttons again. Pressing the „Enter“-button saves the DMX-address.

The address can also be adjusted with a RDM-capable desk or the RDM-controller.

3. Put the Fader at the DMX-desk to > 66% (169) => Pumping station will be activated.

Will the Fader be adjusted between 33% (85) and 66% (169), the pumps will be deactivated, the valve opens and the fog fluid in the rising tube will drain. The fluid in the reservoirs will not drain.

The bleed valve closes as soon as the pressure is sunken to a minimum, at least after three minutes.

Will the Fader be adjusted < 33% (85), the Pumping station will be deactivated **without** opening the valve. The pressure remains constant.



Fig. 4 Main menu

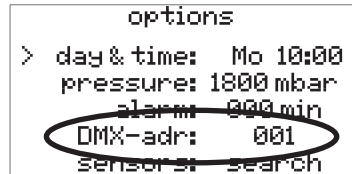

Fig. 5 Menu Options, adjusting the DMX-address

2. Operation

2.4 Operation with the internal Timer

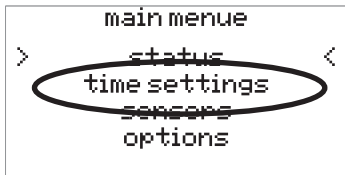

Fig. 6 Main menu

block	start	stop
01	Mo 15:00	Tu 05:00
02	Mo 00:00	Mo 00:00
03	Mo 00:00	Mo 00:00
04	Mo 00:00	Mo 00:00

Fig. 7 Menu Time settings, programming the time blocks

block	start	stop
> 01	Mo 15:00	Tu 05:00
02	Mo 00:00	Mo 00:00
03	Mo 00:00	Mo 00:00
04	Mo 00:00	Mo 00:00

Fig. 8 Status menu, showing the programmed time blocks

ATTENTION: the Pumping station only shows the European 24 hours! For the pm-time you have to add 12 hours to get the 12 hrs time.

In the menu „time settings“ 16 different „time blocks“ with Start- and Stop-time and the day can be programmed in. The Pumping station then works only during the adjusted time period.

If the station shall work f.e. from Monday 15:00 (= 03:00 pm) to Tuesday 05:00 am, the block will look like this: Mo 15:00 Di 05:00 (Fig. 7).

To activate a block, Start- and Stop-time must differ.

Once the programmed Start-time has been achieved, the Pumping station start working automatically. The activated time block will be shown in the timeline at the display (Fig. 8).

1. Press the „Menu“-button to attain the main menu, choose „Time settings“ by using the „Up“-/„Down“-buttons and activate it by pressing the „Enter“-button. Choose the requested „time block“ with the „Up“- / „Down“-buttons.
2. Press the „Enter“-button, to activate the first value (day). The value blinks and can be changed by pressing the „Up“- and „Down“-buttons. Pressing the „Enter“-button again will activate the next value. Repeat until all values has been adjusted.

Pressing the „Enter“-button after programming the Stop-time will save the block and its values.

2. Operation

2.5 Main menu

The main menu can be selected by pressing the „Menu“-button.

Using the „Up“-/„Down“-buttons, the submenu can be selected and adjustments can be made, pressing the „Enter“-button confirms the selection or switches on to the next image.



Fig. 9 Main menu showing diagram of the submenus

2.5.1 Submenu „Status“

Diagram with timeline, time, activity (active/draining/not active), DMX-status and RDM-Identify-Text.

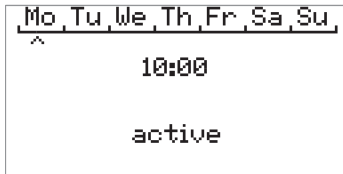

Fig. 10 Submenu Status, Station active

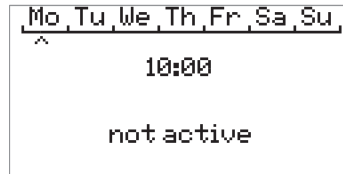

Fig. 11 Submenu Status, Station not active

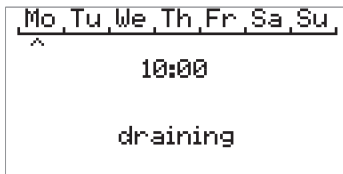

Fig. 12 Submenu Status, Fluid draining

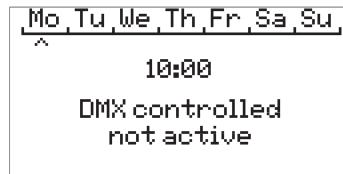

Fig. 13 Submenu Status, DMX-desk connected, Station not active

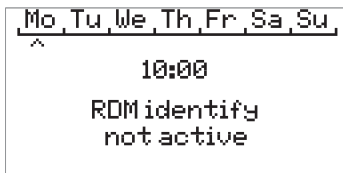

Fig. 14 Submenu Status, RDM-Identifying, Station not active

2. Operation

2.5.2 Submenu „Time settings“

Menu to programm in the time blocks into the internal Timer. See chapter 2.4 „Operation with the internal Timer“.

2.5.3 Submenu „Sensors“

The sensors are located in the lid of the fluid reservoirs and can be connected to the Pumping station optionally. These sensors overview the functionality of the reservoirs and notify interferences to the Pumping station.

If sensors are connected, a list of these will show up in the submenu „Sensors“.

- Selection of a sensor with the „Up“-/“Down“-buttons, details about it via „Enter“.
- Small „o“ means OK, small „x“ shows a defective kommunikation.
- If a sensor reports an overflow, the Pumping station will be switched off. Thus avoids an overflowing of the fluid reservoirs. An error indication appears at the display (see chapter 3).

```
sensors
no sensors
found!
```

Fig. 15 Submenu Sensors, sensor not found, no sensor connected

```
sensors
-----|-----|-----
> 01 | 012114 | o
```

```
sensor details
s/n: 012114
type: overflow
value: OK
```

Fig. 16 Sensor with serial number found, Type (type) Status (value): ok

```
sensors
-----|-----|-----
> 01 | 012114 | x
```

```
sensor details
s/n: 012114
type: overflow
value: error
```

Fig. 17 Sensor with serial number found, Type (type) Status (value): error indication

2. Operation

2.5.4 Submenu Options

```
options
> day& time: Mo 10:00
  pressure: 1800 mbar
    alarm: 000 min
  DMX-adr: 001
  sensors: search
```

Fig. 18 Submenu Options showing diagram of the adjustable values

Several parameter can be adjusted in this submenu:

1. Day & time

Adjusting the time with „Up“-/“Down“-buttons, confirming with the „Enter“-button (see chapter 2.1, episode 5).

2. Pressure

Desired pressure in the tube. While the Pumping station is activated, the indicated value will be compared to the adjusted must value. If the indicated value is smaller than the adjusted must value, the pumps will be activated. Must value and indicated value are not and do not have to be adjusted to exactly millibar. The adjustment of the must valve is made in steps of 50 mbar. The must value is only a guide value.

The higher the fluid reservoirs are located and the longer the tubes are, the higher the must value has to be.

When delivered the must value is adjusted at 1800 mbar. This value is good enough for most implements.

3. Alarm

This value specifies the maximum continuous running time of the pumps. When delivered the value is 000. This means the pumps are running until the must value is reached.

If the must value will not be reached within the adjusted time, the Pumping station assumes a leak in the tube or an emptied fluid barrel. An error accures on the display.

Attention: The must value will also not been reached if the value is 000, the mechanical protection (float assembly) in the fluid reservoir fails and no Sensors have been connected. The pumps will pump until the barrel is emptied! The fluid reservoirs will overflow.

To avoid this, a time value can be programmed in. This enables the Pumping station to refill all reservoirs after the fogging process and reach the adjusted must value in the tube.

It also ensures that the pumps will only pump fluid out of the barrel for the duration of the programmed time, even if the unit is defectiv.

2. Operation

4. DMX-address

Adjusting the DMX-address with „Up“-/“Down“-buttons, save with „Enter“-button.

5. Sensors

„Sensors: Search“: pressing the „Enter“-button provokes a restart for searching Sensors at the sensor bus.

The amount of located Sensors will be mounted, the display shows „Sensors: xx found“.

During the search the entry change to „Search: Abort“. The search can be aborted by pressing the „Enter“-button. The list of Sensors will be deleted.

3. Error indication

Overfull

Will be shown is a Sensor noted a filling level that is too high.

=> Check fluid reservoir(s)

```
alarm: fluid reservoir  
overfull
```

```
s/n: 012114
```

No fluid

Will be shown when the adjusted alarm time is exceeded (see chapter 2.5.3).

=> Check whether there are holes in the tube

=> Check fluid level of the connected barrel

=> Rise alarm time if needed

=> Reduce must value if needed

```
alarm: tube broken  
or no fluid
```

4. Technical Data

Voltage

110 V - 230 V

Power requirement

80 Watt

Dimensions (L x W x H) incl. holders

36 x 36 x 23 cm

Weight

11.3 kg

Manufactured for:

Look Solutions - Fog machines made in Germany · Bünteweg 33 · DE - 30989 Gehrden

5. Fluid reservoir

Fluid reservoir with hanging yoke

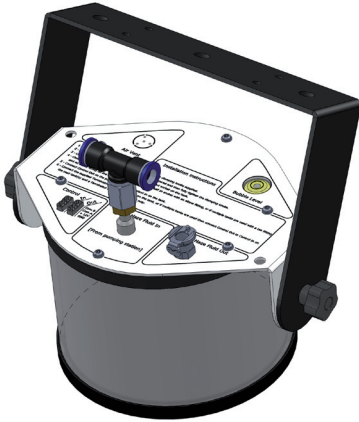

Fluid reservoir with tank holder for Viper nt/Viper 2.6

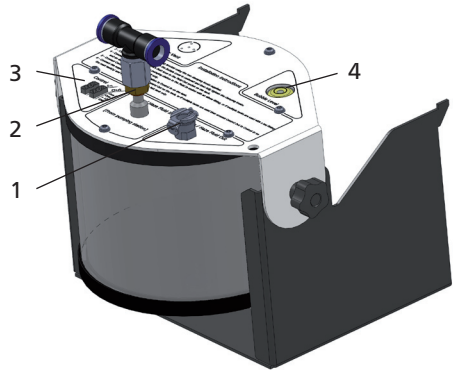

1. Quick-acting coupling to connect the tube from the fog machine
2. T-connector to connect the reservoir to the pumping station and/or to connect several fluid reservoirs
3. Sensors (to communicate with the Pumping station the Sensors have to be connected to the sensor bus)
4. Water level to adjust the fluid reservoirs exactly. The bubble has to be located exactly in the middle to ensure the function of the fluid reservoir.

Draining the fluid from the reservoir

The fluid can be drained by unscrewing the small screw at the bottom of the reservoir. Make sure a canister is placed under the reservoir to absorb the draining fluid.

The reservoirs can also be emptied by starting the fogging process while the Pumping station is switched off.

Following connectors are available to connect the tubes from the Pumping station and inbetween the fluid reservoirs:

T- & Y-connector

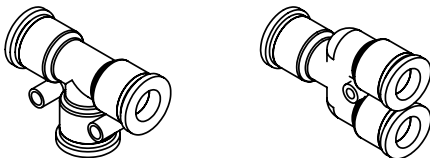

Straight & L-connector

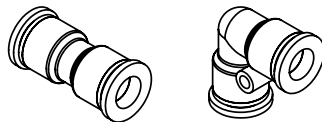

6. Garantiebestimmungen

Für die von Ihnen erworbene **Pumpstation** leistet Look Solutions Garantie gemäß nachfolgenden Bedingungen:

1. Wir beheben unentgeltlich nach Maßgabe der folgenden Bedingungen (Nr. 2 bis 6) Schäden oder Mängel am Gerät, die nachweislich auf Werksfehlern beruhen, wenn sie uns unverzüglich nach Feststellung und innerhalb 24 Monaten nach Lieferung an den Endabnehmer gemeldet werden. Eine Garantiepflicht wird nicht ausgelöst durch geringfügige Abweichungen von der Soll-Beschaffenheit, die für Wert und Gebrauchstauglichkeit des Gerätes unerheblich sind, durch Schäden aus Einwirkung von Wasser sowie allgemein aus anormalen Umweltbedingungen oder höherer Gewalt.
2. Die Garantieleistung erfolgt in der Weise, daß mangelhafte Teile nach unserer Wahl unentgeltlich instandgesetzt oder durch einwandfreie Teile ersetzt werden. Geräte, für die unter Bezugnahme auf diese Garantie eine Garantieleistung beansprucht wird, sind an unsere Service-Stationen zu übergeben oder frei Haus einzusenden. Die Anschrift der Service-Stationen erfahren Sie bei Ihrem Fachhändler oder dieser sendet das Gerät für Sie ein. Dabei ist der Kaufbeleg mit Kauf- und/oder Lieferdatum vorzulegen. Ersetzte Teile gehen in unser Eigentum über.
3. Der Garantieanspruch erlischt, wenn Reparaturen oder Eingriffe von Personen vorgenommen werden, die hierzu von uns nicht ermächtigt sind oder wenn unsere Geräte mit Ergänzungs- oder Zubehörteilen versehen werden, die nicht auf unsere Geräte abgestimmt sind. Desweiteren erlischt der Garantieanspruch bei nachweislicher Mißachtung der Bedienungsanleitung bzw. bei Fehlern durch unsachgemäße Behandlung/ Handhabung sowie bei Schäden aus Gewalt- einwirkung.
4. Frachtkosten, die in Zusammenhang mit der Erbringung der Garantieleistung entstehen, trägt grundsätzlich der Einsender/Kunde.
5. Garantieleistungen bewirken weder eine Verlängerung der Garantiefrist, noch setzen sie eine neue Garantiefrist in Lauf. Die Garantiefrist für eingebaute Ersatzteile endet mit der Garantiefrist für das ganze Gerät.
6. Sofern ein Schaden oder Mangel von uns nicht beseitigt werden kann, oder die Nachbesserung von uns abgelehnt oder unzumutbar verzögert wird, wird innerhalb von 6 Monaten ab Kauf-/ Lieferdatum auf Wunsch des Endabnehmers entweder
 - kostenfrei Ersatz geliefert oder
 - der Minderwert vergütet oder
 - das Gerät gegen Erstattung des Kaufpreises, jedoch nicht über den marktüblichen Preis hinaus, zurückgenommen.
7. Weitergehende oder andere Ansprüche, insbesondere solche auf Ersatz außerhalb des Gerätes entstandener Schäden, sind – soweit eine Haftung nicht zwingend gesetzlich angeordnet ist – ausgeschlossen.

Wir/we/nous OTTEC Technology GmbH

Anschrift/ address/ adress Bünteweg 33
DE – 30989 Gehrden
Germany

erklären in alleiniger Verantwortung, daß das Produkt
declare under our sole responsibility, that the product
declarons sous notre seule responsabilité, que le produit

Bezeichnung/ name/ nom **Pumpstation
Pumping station
Station de pompage**

Typ/ type/ type **Pumpstation**

mit den Anforderungen **EN 55014 Teil 1/Part 1** : Generic emission standard
der Normen übereinstimmt **EN 55014 Teil 2/Part 2** : Generic immunity standard
fulfills the requirements of the standard **EN 60335-1** : Electrical safety
satisfait aux exigences des normes **VDE 0700 Teil 245/Part 245** : Electrical safety

Das Produkt erfüllt somit die Forderungen der EG-Richtlinie
Therefore the product fulfills the demands of the following EC-Directive
Le produit satisfait ainsi aux conditions des directives suivantes de la CE

2004 / 108 / EG

Richtlinie über die elektromagnetische Verträglichkeit
Directive relating to electromagnetic compatibility
Directive relatives à la compatabilité électromagnétique

2006 / 42 / EG

Maschinenrichtlinie
Machinery directive
Directive relative aux machines

Gehrden, 01.04.2014

Jörg Pöhler

Ort, Datum der Ausstellung
Place and Date of Issue
Lieu et date d'établissement

Name u. Unterschrift/Name a. signature/Nom et signature
des Geschäftsführers u. Dokumentationsbevollmächtigten
of the Director and Agent for documentation
de la Directeur et Agent de documentation